

Zartek

**CDP-808 Multi Wireless Intercom System
Installers Manual**



ZA-610 Gate station complete including power supply, relay board and external antenna

ZA-611 Back/side Gate station including power supply, relay board and external antenna

ZA-612 Programming kits including cable and software

ZA-613 Handsets with charger

Overview:

The Zartek Wireless Multi Intercom System is newly developed and three years of R&D in the making. It is fully approved by ICASA. Applications for this system include housing complexes, apartments and office blocks, large estates, long driveways etc. This system can accommodate **100 separate channels**. Communication is initiated from the gatestation by selecting a **3 digit code** such as 001 or 901 and pressing the # button. Only the selected houses handset will ring and communication is established. Communication is **simplex** so only one person can speak at a time but the **gatestation's microphone is always active** so the visitor does not have to press any key to speak. The inside **handset can enter into the conversation** at any time by pressing a PTT button. There are **2 triggers** that can be activated from the handset for opening a motorized gate or striker lock. **Multiple handsets** can be added for the same house to have internal communication. Range is terrain dependant and is **350m in built-up areas and 800m line-of-sight**. The **external antenna** is mounted as high as possible for improved coverage and audio.

Note: This Installers manual is intended to explain programming and installation, please refer to the User's manual for operating instructions.

Setup Procedure:

- 1) Charge gatestation and handsets for at least 2 hours before programming and testing.
- 2) Program one code on gatestation manually or via PC. Do not program or pair gatestation outside; it is easier and better to do all programming on a table before going on site.
- 3) Pair handsets to programmed codes.
- 4) Place gatestation near gate (wall or gooseneck). Connect external antenna to gatestation and mount temporarily for testing.
- 5) Do range tests to furthest point of usage. Test handset audio and gate triggering in actual house or unit. Press code on gatestation and answer on handset.
- 6) Place antenna higher if more range is required.
- 7) If range test is successful, program all names and unit codes.
- 8) Pair each handset or handsets on same code individually.
- 9) Once all paired, test communication from each handset.
- 10) Mount gatestation and external antenna. Connect to fixed power and gate controller board.
- 11) Place each handset in unit and do final communications test.

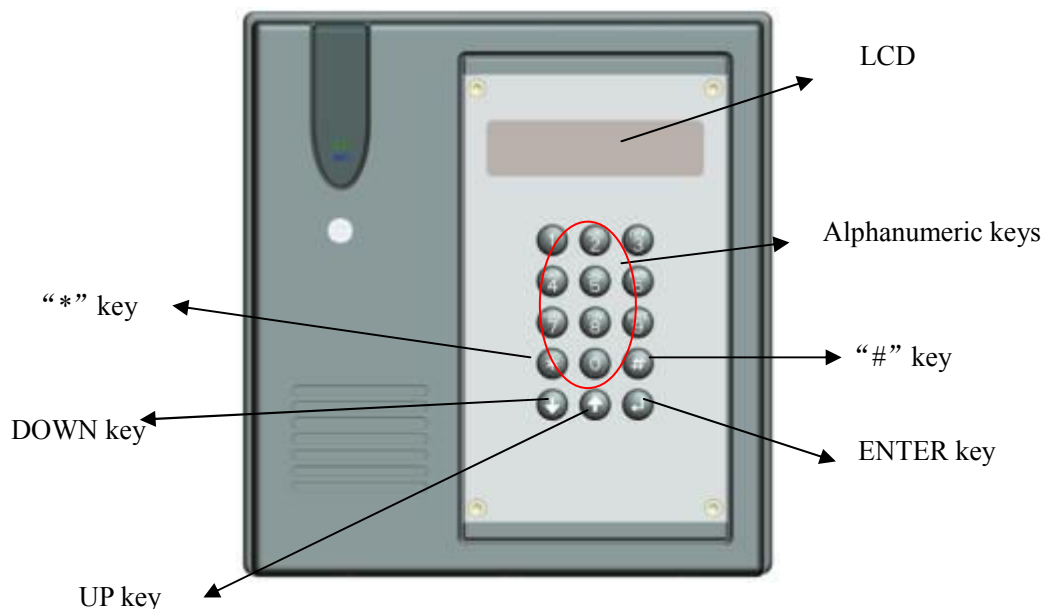

Power

Use only the supplied 12v DC supply. It is a switching power supply which has more stable voltage output than an AC adapter. Connect 12v wires to connection block at the back of the intercom. There is no polarity needed. Do not use any other supply such as 12v battery back-up systems. Insert the Li-ion battery connector into the Li-ion battery socket (refer to Figure below) and connect the power supply. The battery will charge when connected to 12v DC. Use battery power for programming and range testing. In case the gate station is not used for a long period of time, it is recommended to disconnect the battery connector from the socket, otherwise the Li battery will run flat. In case of power outage, the battery will last for 4-5 hours under normal usage.

Programming

Programming can be done manually or via a PC. If there are multiple houses is recommended to use PC programming to enter all the house names and numbers. Manual programming is used to make small changes, add new houses or program a few users. Once the gatestation is programmed with names and unit numbers the handsets can be paired.

Manual Programming

- 1) Press **168 to enter programming mode. In case of wrong entry, the unit will automatically switch back to standby mode.
- 2) The LCD will prompt you to select PC or Manual programming. Use UP/DOWN key to select MANUAL then press ENTER key. Now enter the 6 digit PIN (factory default setting is 11111). In case PIN is wrong, the unit will allow you 3 times to try before switching back to standby mode. Note : It is necessary to remember your programmed PIN (mentioned in following steps) to enter Manual programming.
- 3) Select the operating channel (1-4) using the UP/DOWN key, then press ENTER key. There are 4 channels to select from as there are 4 different frequencies. If there is interference on one channel it is recommended changing the channel. Note all the handsets have to be set on the same channel.
- 4) Enter your preferred PIN, then press ENTER key Use UP/DOWN key to move the flashing

mark left or right.

- 5) Enter your preferred Door Entry code (4 digit), then press ENTER key. Use UP/DOWN key to move the flashing mark left or right.
- 6) Select SINGLE USER or MULTIPLE USER using UP/DOWN key, then press ENTER key.

(I) If SINGLE USER is selected, enter residence name and house no.

Note : It is necessary to assign a house no. (any 3 digit between 001 – 999) even to a single user, otherwise pairing process (mentioned below) cannot proceed properly.

(II) If MULTIPLE USER is selected, enter all residence names and respective house no. (any 3 digit between 001 -999)

Use UP/DOWN key can cause the flashing mark to move left or right.

Use * key to erase a wrong entry

Use # key to change the page

Use alphanumeric keys to select alphabets. Each residence name has only a maximum of 12 letters

The unit can only accept maximum 100 different house no.

After finishing programming all residence names and house no., press ENTER key to exit back to standby mode.

Note : During programming, if no key is pressed within 60 seconds, the unit will automatically exit back to standby mode.

Outline of manual programming steps:

Press **168

select MANUAL and enter

Enter 6 digit PIN

Use arrow keys to select character or number to change (one at a time)

Press # to go to the next page

Press enter to save and exit programming mode.

PC Programming

Install the programming software in PC with the supplied CD.

Select PC programming after entering **168. LCD will show “ PC PROGRAMMING MODE ”

Connect the programming cable between PC Programming connector as shown in Fig 4 and the PC USB port.

Click on the CDP-808 icon on PC and start the programming procedure.

Read from the gatestation (left icon: gatestation to PC)

Enter User name, number, channel select, ID select (only use 1-10), Door entry code, User mode and Pin.

Click apply and then write to gatestation (right icon: PC to gatestation)

Note: It is advised to save the file for future reference

1. Channel selection (the same operating channel must be selected on gatestation and all handsets)

Take out battery from handset, keep K1 pressed in while inserting the battery, the unit will enter channel selection mode. Press K7 and K9 to select the preferred channel then take out battery again. Install back battery and press K2 to switch on unit.

2. Pairing (Place the handsets and gatestation on a flat surface such as table when doing pairing)

Take out battery from handset, keep K4 pressed in while inserting the battery, the unit will enter pairing mode and the LCD will show a "P" flashing. Now place the handset near to a gate station on a flat surface.

3. Gatestation into Pairing mode

Press **238 when the unit is under standby mode.

Enter the 6 digit PIN, if the entered PIN is correct, the LCD will show "PAIRING", indicating the unit is in PAIRING mode.

Now select a house no. such as 001 that is already programmed into the unit, then press ENTER key. The word "PAIRING" starts flashing in the LCD. Make sure there is at least one handset (or handsets if you need multiple handset for same house no.) also under PAIRING mode nearby. Once the handset receives the signal from gate station successfully, the selected house no. will be shown in the LCD of handset.

Note : If the selected house no. is not a no. that is previously programmed into the unit, PAIRING will not be executed (the word "PAIRING" will not flash in the LCD). The unit will return back to standby mode after 3 incorrect entries.

4. Handset pairing

The LCD will initially show "000" and then show the paired house no. once the pairing process is successful. Take out battery from handset, install back again and press K2 to switch on unit, the handset is now ready for operation.

Note: In case the house no. shown on LCD is different from the intended pairing no., repeat pairing process again.

5. All handsets

The pairing process should be carried for every house no. programmed in the unit so that there is at least one handset paired with each house no.

6. Backgate station

Once the front gate station is paired to the respective handsets, use PC programming to read all the data stored in front gate station and then write such data into the back gate station.

Outline of pairing process steps:

Take handset/s and get into Pairing mode

Press **238 on gatestation and enter 6 digit PIN to begin pairing

Place all handsets and gatestation flat on table

Press 3 digit code to be paired to handsets and press enter

Code should be displayed on handset within a few seconds

Repeat process with each handset and code

Back gatestation

It is possible to add an additional gatestation to be used on another entrance or exit, for instance to be notified when visitors want to exit. The functions of the back gatestation are similar to the front station as all the same names and codes are stored on the station. Gate triggering is limited in that a call has to be initiated from the back gatestation in order to be able to trigger the gate it is connected to.

Programming a gatestation:

Once the front gate has been programmed and all the handsets paired the front gate will be able to clone a backgate station. Note that if any changes are made to the front gate programming such as new names, numbers or additional handsets, the back gate will need to be updated again via PC cloning.

Enter PC programming mode on both the front and back gate

Connect the front gate to the PC using the cable and READ from gatestation (left icon).

The PC will load all the programming on the screen

Now connect the back gate station and WRITE to station (right icon)

The station is ready to use.

System busy function (if required)

This function is used to block any communication from either front or back gatestation whilst another conversation is in progress. A hard wire connection is required between the 2 gatestations. There is a 3 core wire coming from the back of each gate station, the colour of wires are red, white and black. Connect red to red, black to black and white to white.

If you do not connect these wires, the gate station will still perform normally but will not have the system busy function.

When either the front or back station is making call, the remaining station cannot make any calls until the station in use finishes the call. The screen of remaining station will show:

“SYSTEM IN USE PLEASE WAIT”

Above text will be shown until the station in use finishes the call. In case a visitor tries to make a call when this text is shown on screen, the station will just ignore the input and provide no response.

When two visitors approach the front and gate station at same time and try to make a call, the visitor who first press the CALL button can initiate the call, the remaining station cannot make a call and screen will show “ SYSTEM IN USE PLEASE WAIT”

Reset to factory/default setting

Under standby mode, short circuit the two solder pads A & B for over 25 sec (with power supply connected), all programmed data will be erased and the unit returns to factory default setting. (i.e. PIN is 111111). The gatestation can also be reset using the PC programming and clicking the “Return to factory settings” button

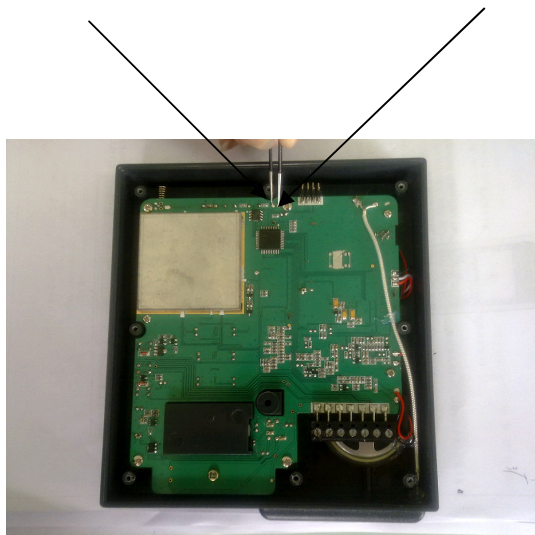

Range and External antenna

The gatestation has been designed to be used with an external antenna. Typical range with the antenna mounted is 350m in built-up areas and 800m line-of-sight. Further range is possible with higher placing of the antenna. Place the external antenna in a vertical orientation on top of poles, walls or a roof. It is important to place the antenna away from metal or concrete. If the antenna must be placed against a wall or building, range will be good in front of the building but low behind the structure. The antenna mount uses a “L” bracket and includes plugs and screws. Connect the cable at the back of gatestation to the antenna cable and ensure that the ends are fitted tightly. Extra 3m lengths of cable are available although it is advised not to exceed the length by 10m as power will be lost.

Gate Triggering

The gatestation has 2 separate triggers used to opening/closing gates. Both gates can be triggered from the handset. During a call the door lock button is pressed once to activate and under standby the buttons must be pressed in for 3 seconds in order to trigger. The trigger function can be deactivated on the handset.

The contacts are located at the back of the intercom. Lock A is a 1amp pulse output of the 12V supply. This is used to trigger strike locks such as used for pedestrian gates. If Lock A is used to trigger a standard gate motor it is essential to use the supplied relay board as shown in the figure below. Lock B is a dry contact which is normally open. Once the Lock B trigger is activated the pins of Lock B will connect and make a short circuit and close. This connection can be connected directly to the gate controller board of a gate motor. A standard receiver can also be connected on the gate controller board in parallel with the gatestation if remotes are required.

Connection to a gate motor using DC power

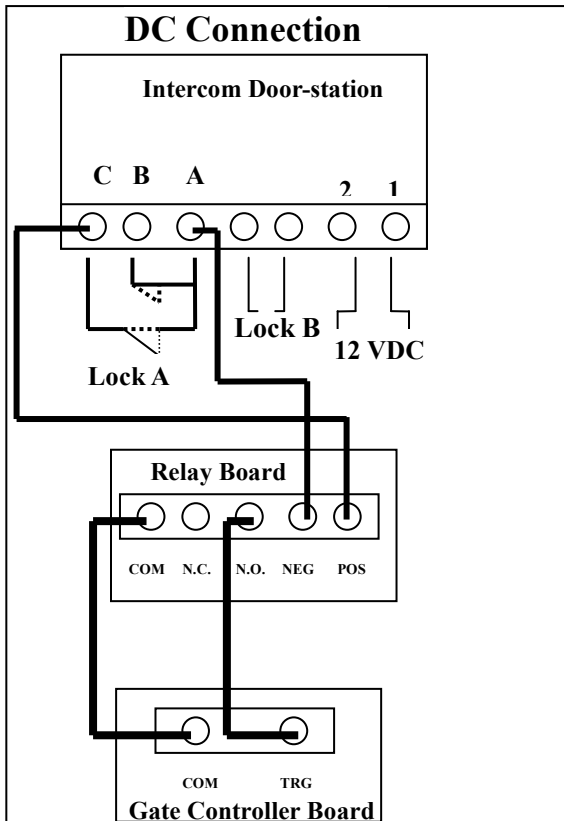

There is **no required polarity** for the DC connections although the relay board has polarity. If pin 1 is 0v and pin2 12v, so pin A will be 0V and pin C 12v when triggered. Connect the relay board as shown with Pin A to the Neg (0V) contact and Pin C to the Pos (12V) contact. The relay has a LED light which will light-up when triggered. Connect the Com and N.O. pins of the relay board to the Com and Trg pins on the gate controller board.

Mounting of Caller Unit

The mounting bracket is removed by first unscrewing the 4 screw of the aluminum plate and then the 4 screws of the keypad bracket using the supplied special tool. Gently remove the rubber keypad as shown in the figure below

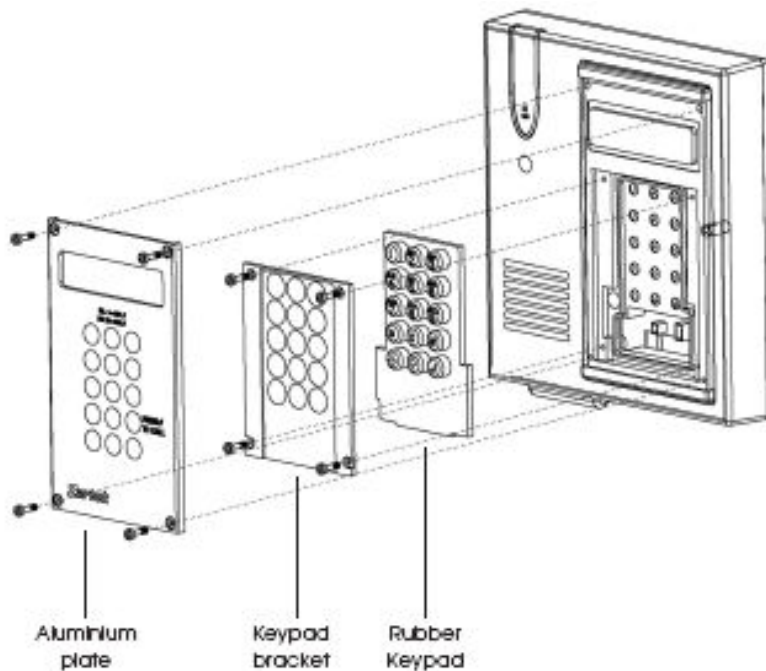

Unscrew the bolt holding the mounting bracket to the gatestation as shown in the figure below.

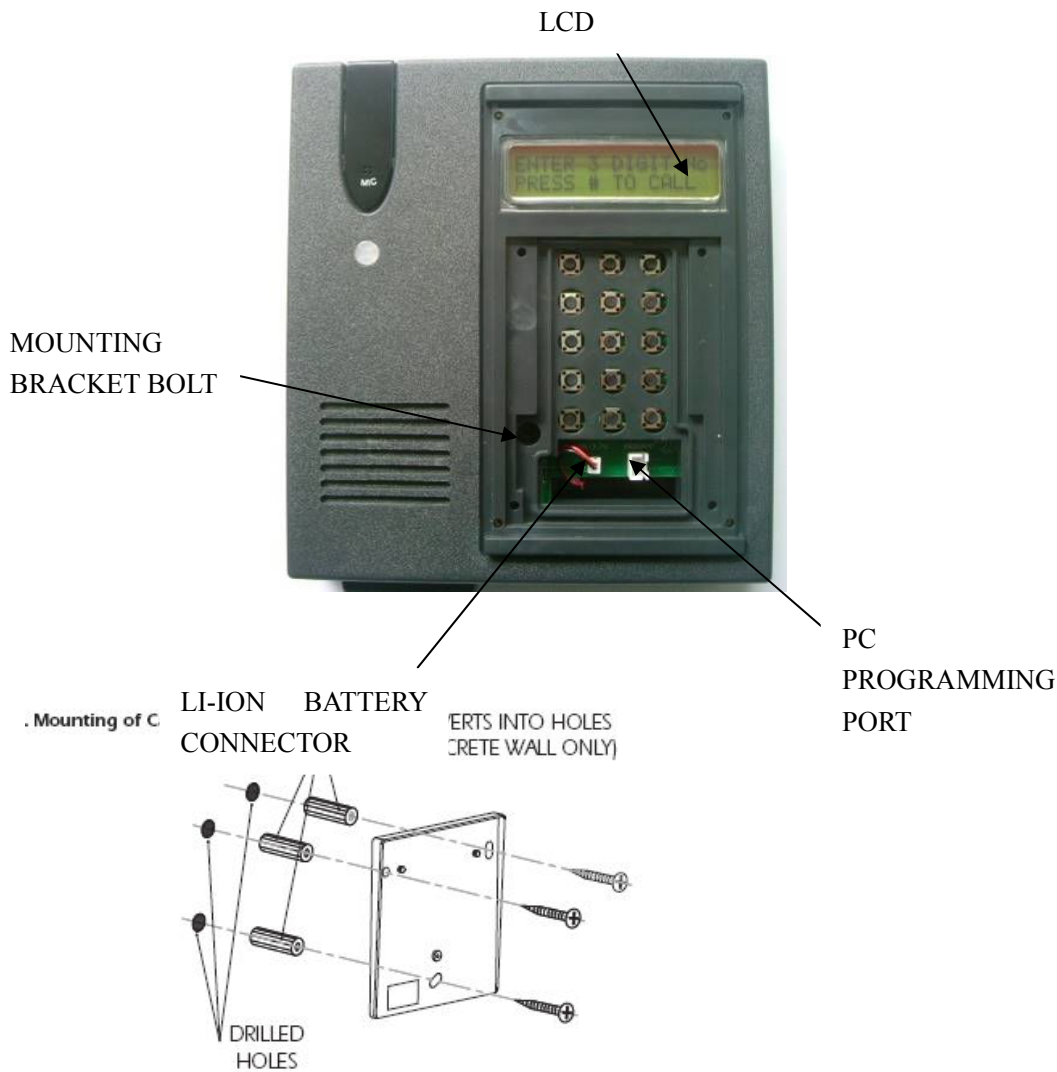

1. The caller unit has been designed to be splash and rain proof. Ensure that the rubber buttons, keypad bracket and plate cover are fitted well when installation is complete.
2. Select a location near your door entrance against a wall. The gatestation can be mounted against a gooseneck and be covered with a metal housing as the antenna is external and range will not be affected.
3. It is advised that the intercom is not installed in the vicinity of other electronic devices that may reduce the operating range such as electric fences, cameras etc.
4. Use the supplied self tap crews to fix the mounting bracket onto the wall. The supplied paper mask at the end of this manual can be helpful in drilling the correct position of holes.
5. Align the two rivets on the mounting bracket with the holes of the metal hangers on the back of the caller unit, make contact and slide the unit upward. Screw in the supplied machine screw to fix the caller unit in position.

The caller unit is housed in a high impact ABS/PC cabinet strengthened by an aluminum alloy front cover to achieve professional grade ruggedness required in most outdoor application. Rubber gaskets seals around all joints and terminals keep out dust, rain, snow and spray, assuring years of reliable operation even in harsh environment. The unit meets to IP-54 standard and can operate from -30°C to 55°C.

Important terms

OPERATING CHANNEL: There are 4 channels to select from as there are 4 different frequencies. If there is interference on one channel it is recommended changing the channel. Note all the handsets have to be set on the same channel.

PIN: This is a 6 digit secure code which protects the manual programming mode. No pin is needed for PC programming.

DOOR ENTRY CODE: This is a 4 digit code used to trigger the gate from the gatestation. This is useful for residents and visitor trusted with the code to gain entry without calling or remote controls.

3 DIGIT CODE: This is a number consisting of 3 digits such as 001, 111, 999 etc assigned for each house. The visitor can search for the digit and press it on the gatestation keypad to ring a certain house. Each handset will display their unique code. Note: 1 or 2 digit codes will not work.

PAIRING: Each handset must be linked to the gatestation. Pairing is where the handset learns the unique code from the gatestation.

PROGRAMMING: The house name and number information as well as other information must be entered into the memory of the gatestation.

PTT: Push-To-Talk is the method for conducting a conversation with a simplex device. The resident can answer calls and reply by pressing the PTT button on the handset. Press and hold down the PTT button when speaking into the microphone.

